

TAG: _____

Specification

Downflow / Horizontal Gas Furnace - Variable Speed - 2 Stage Heat

ADD2B060A9V3VA

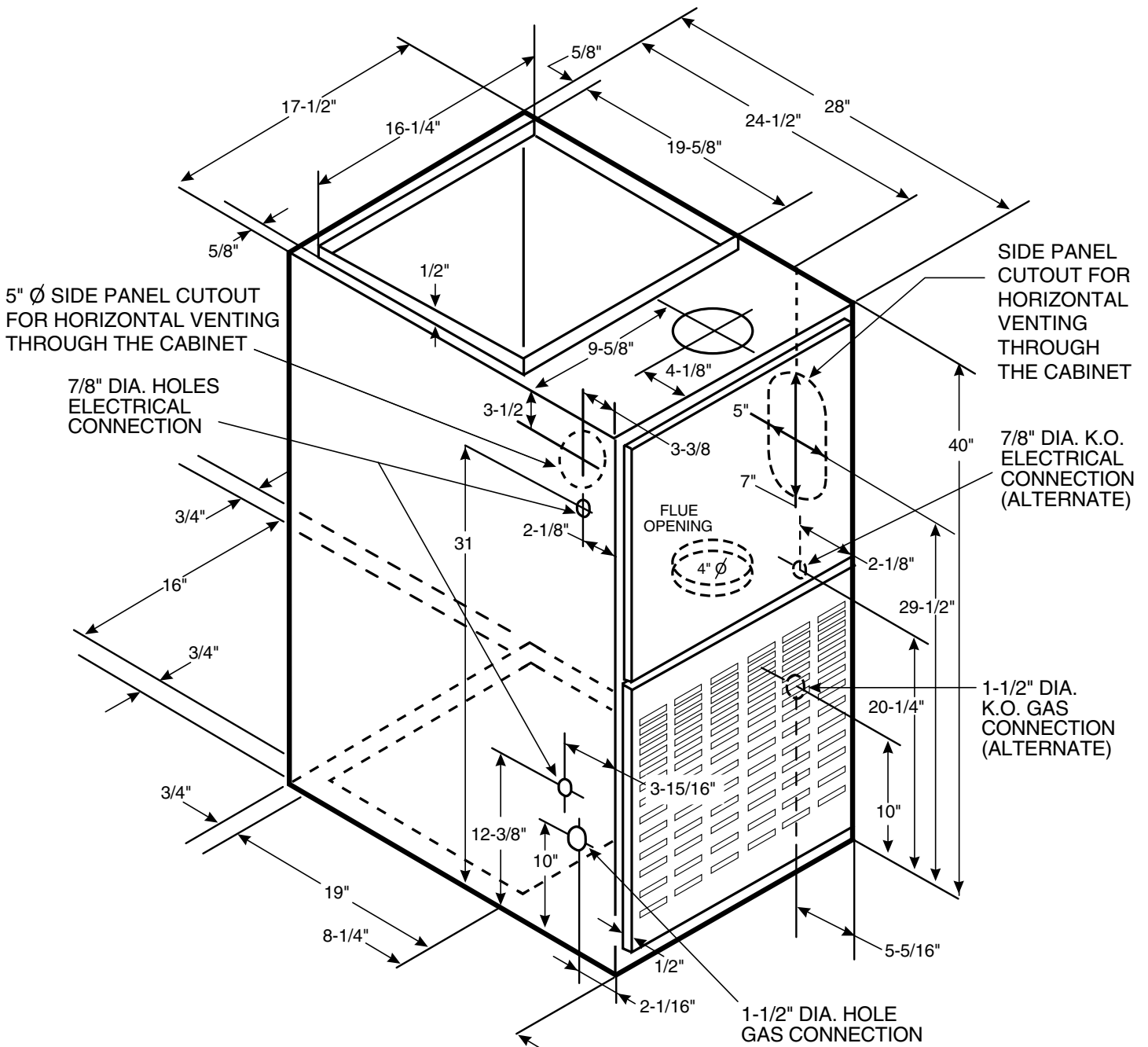

| *DD2B060A9V3VA FURNACE HEATING AIRFLOW (CFM) AND POWER (WATTS) VS. EXTERNAL STATIC PRESSURE WITH FILTER | | | | | | | | | |
|---|-----------------|--------------------|-----|------------|--------------------------|------|------|------|------|
| | AIRFLOW SETTING | DIP SWITCH SETTING | | | EXTERNAL STATIC PRESSURE | | | | |
| | | SW7 | SW8 | | 0.1 | 0.3 | 0.5 | 0.7 | 0.9 |
| HEATING 1ST STAGE | LOW | ON | ON | CFM | 547 | 593 | 571 | 567 | 544 |
| | | | | TEMP. RISE | 53 | 49 | 51 | 51 | 53 |
| | | | | WATTS | 48 | 80 | 107 | 143 | 170 |
| | MEDIUM ** | ON | OFF | CFM | 658 | 664 | 658 | 658 | 652 |
| | | | | TEMP. RISE | 44 | 44 | 44 | 44 | 44 |
| | | | | WATTS | 65 | 92 | 122 | 155 | 197 |
| | HIGH | OFF | OFF | CFM | 735 | 761 | 761 | 764 | 762 |
| | | | | TEMP. RISE | 39 | 38 | 38 | 38 | 38 |
| | | | | WATTS | 75 | 120 | 155 | 190 | 230 |
| HEATING 2ND STAGE | LOW | ON | ON | CFM | 743 | 777 | 775 | 783 | 772 |
| | | | | TEMP. RISE | 60 | 57 | 57 | 57 | 58 |
| | | | | WATTS | 75 | 120 | 155 | 195 | 230 |
| | MEDIUM ** | ON | OFF | CFM | 874 | 887 | 881 | 894 | 894 |
| | | | | TEMP. RISE | 51 | 50 | 50 | 50 | 50 |
| | | | | WATTS | 105 | 150 | 185 | 230 | 270 |
| | HIGH | OFF | OFF | CFM | 996 | 1013 | 1041 | 1058 | 1069 |
| | | | | TEMP. RISE | 45 | 44 | 43 | 42 | 42 |
| | | | | WATTS | 143 | 192 | 250 | 307 | 337 |

| *DD2B060A9V3VA FURNACE COOLING AIRFLOW (CFM) AND POWER (WATTS) VS. EXTERNAL STATIC PRESSURE WITH FILTER | | | | | | | | | | | |
|---|-------------------------|--------------------|-----|-----|-----|--------------------------|------|------|------|------|------|
| OUTDOOR UNIT SIZE (TONS) | AIRFLOW SETTING | DIP SWITCH SETTING | | | | EXTERNAL STATIC PRESSURE | | | | | |
| | | SW1 | SW2 | SW3 | SW4 | 0.1 | 0.3 | 0.5 | 0.7 | 0.9 | |
| 1.5 | LOW (350 CFM/TON) | ON | ON | OFF | ON | CFM | 533 | 563 | 546 | 534 | 515 |
| | | | | | | WATTS | 45 | 75 | 100 | 130 | 160 |
| | NORMAL (400 CFM/TON) | ON | ON | OFF | OFF | CFM | 609 | 627 | 624 | 606 | 607 |
| | | | | | | WATTS | 55 | 90 | 115 | 150 | 180 |
| | HIGH (450 CFM/TON) | ON | ON | ON | OFF | CFM | 664 | 683 | 690 | 687 | 680 |
| | | | | | | WATTS | 65 | 95 | 135 | 165 | 200 |
| 2 | LOW (350 CFM/TON) | OFF | ON | OFF | ON | CFM | 693 | 714 | 708 | 706 | 712 |
| | | | | | | WATTS | 65 | 105 | 135 | 170 | 210 |
| | NORMAL (400 CFM/TON) | OFF | ON | OFF | OFF | CFM | 780 | 821 | 813 | 810 | 816 |
| | | | | | | WATTS | 85 | 130 | 165 | 205 | 245 |
| | HIGH (450 CFM/TON) | OFF | ON | ON | OFF | CFM | 886 | 896 | 901 | 925 | 930 |
| | | | | | | WATTS | 110 | 150 | 200 | 250 | 285 |
| 2.5 | LOW (350 CFM/TON) | ON | OFF | OFF | ON | CFM | 865 | 882 | 869 | 884 | 885 |
| | | | | | | WATTS | 105 | 145 | 185 | 275 | 265 |
| | NORMAL (400 CFM/TON) | ON | OFF | OFF | OFF | CFM | 977 | 983 | 1014 | 1035 | 1019 |
| | | | | | | WATTS | 135 | 180 | 235 | 290 | 330 |
| | HIGH (450 CFM/TON) | ON | OFF | ON | OFF | CFM | 1097 | 1125 | 1155 | 1169 | 1169 |
| | | | | | | WATTS | 170 | 235 | 305 | 350 | 405 |
| 3 ** | LOW (350 CFM/TON) | OFF | OFF | OFF | ON | CFM | 1006 | 1034 | 1056 | 1072 | 1067 |
| | | | | | | WATTS | 145 | 200 | 255 | 315 | 352 |
| | NORMAL ** (400 CFM/TON) | OFF | OFF | OFF | OFF | CFM | 1169 | 1202 | 1226 | 1221 | 1217 |
| | | | | | | WATTS | 215 | 265 | 355 | 390 | 440 |
| | HIGH (450 CFM/TON) | OFF | OFF | ON | OFF | CFM | 1313 | 1339 | 1360 | 1369 | 1357 |
| | | | | | | WATTS | 290 | 370 | 425 | 500 | 525 |

NOTES:

- *FIRST LETTER MAY BE "A" OR "T"
- **FACTORY SETTING.
- CONTINUOUS FAN SETTING: HEATING OR COOLING AIRFLOW IS APPROXIMATELY 50% OF SELECTED COOLING VALUE.
- FOR VARIABLE SPEED: LOW SPEED AIRFLOWS ARE APPROXIMATELY 30% OF LISTED VALUES.
- LOW 350 CFM/TON IS RECOMMENDED FOR VARIABLE SPEED APPLICATION FOR COMFORT & HUMID CLIMATE SETTING: NORMAL IS 400 CFM/TON: HIGH 450 CFM/TON IS FOR DRY CLIMATE SETTING.

INDOOR BLOWER TIMING

Heating: The ECM Fan Control controls the variable speed indoor blower. The blower "on" time is fixed at 45 seconds after ignition. The FAN-OFF period is field selectable by dip switches #2 and #3 on the Integrated Furnace Control at 60, 100, 140, or 180 seconds. The factory setting is 100 seconds, (See unit wiring diagram).

Cooling: The fan delay-off period is set by dip switches on the ECM Fan Control board connected to the Integrated Furnace Control. The options for cooling delay off is field selectable by dip switches #5 and #6. However, dip switch #1 on the Integrated Furnace Control must be set to "ON" for cooling mode to function properly.

The following table and graph explain the delay-off settings:

** - This selection provides a ramping up and ramping down of the blower speed to provide improved comfort, quietness, and potential energy savings. The graph below shows the ramping process.

COOLING OFF - DELAY OPTIONS

| SWITCH SETTINGS | | SELECTION | NOMINAL AIRFLOW |
|-----------------|---------|-------------|-----------------|
| 5 - OFF | 6 - OFF | NONE | SAME |
| 5 - ON | 6 - OFF | 1.5 MINUTES | 100% * |
| 5 - OFF | 6 - ON | 3 MINUTES | 50% |
| 5 - ON | 6 - ON | ** | 50 - 100% |

* - This setting is equivalent to BAY24X045 relay benefit

** - This selection provides **ENHANCED MODE**, which is a ramping up and ramping down of the blower speed to provide improved comfort, quietness, and potential energy savings. See Wiring Diagram notes on the unit or in the Service Facts for complete wiring setup for **ENHANCED MODE**. The graph which follows, shows the ramping process.

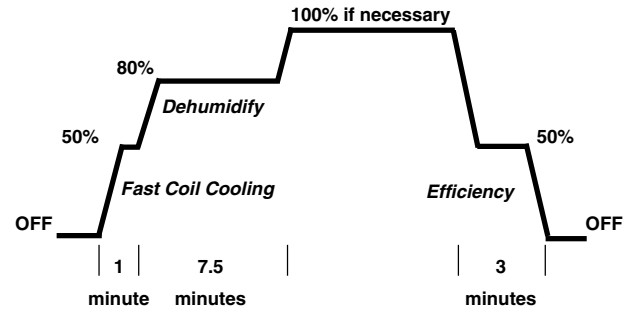

General Data ①

| TYPE | Downflow / Horizontal |
|---------------------------------|-----------------------|
| RATINGS 2 | |
| 1st Stage Input BTUH | 39,000 |
| 1st Stage Capacity BTUH (ICS) 3 | 31,200 |
| 2nd Stage Input BTUH | 60,000 |
| 2nd Stage Capacity BTUH (ICS) 3 | 48,000 |
| Temp. rise (Min.-Max.) °F. | 35 - 65 |
| BLOWER DRIVE | |
| | DIRECT |
| Diameter-Width (In.) | 10 x 7 |
| No. Used | 1 |
| Speeds (No.) | VARIABLE SPEED |
| CFM vs. in. w.g. | See Fan Performance |
| Motor HP | 1/2 |
| R.P.M. | VARIABLE |
| Volts/Ph/Hz | 115/1/60 |
| COMBUSTION FAN - Type | |
| | Centrifugal |
| Drive - No. Speeds | Direct - 2 |
| Motor HP - RPM | 1/100 - 2543 / 1727 |
| Volts/Ph/Hz | 115/1/60 |
| F.L. Amps | 0.70 / 0.40 |
| FILTER — Furnished? | |
| | Yes |
| Type Recommended | High Velocity |
| Hi Vel. (No.-Size-Thk.) Shipped | 2 - 14 x 20 - 1in. |

| | |
|------------------------------------|---------------------------|
| VENT COLLAR — Size (in.) | 4 Round |
| HEAT EXCHANGER | |
| Type-Fired | Alum. Steel |
| -Unfired | |
| Gauge (Fired) | 20 |
| ORIFICES — Main | |
| Nat. Gas. Qty. — Drill Size | 3 — 45 |
| L.P. Gas Qty. — Drill Size | 3 — 56 |
| GAS VALVE | Redundant - Two Stage |
| PILOT SAFETY DEVICE | |
| Type | Hot Surface Ignition |
| BURNERS — Type | |
| | Multiport Inshot |
| Number | 3 |
| POWER CONN. — V/Ph/Hz ④ | |
| | 115/1/60 |
| Ampacity (In Amps) | 10.5 |
| Max. Overcurrent Protection (amps) | 15 |
| PIPE CONN. SIZE (IN.) | |
| | 1/2 |
| DIMENSIONS | |
| | H x W x D |
| Crated (In.) | 41- 3/4 x 19-1/2 x 30-1/2 |
| Uncrated (In.) | 40 x 17-1/2 x 28-1/2 |
| WEIGHT | |
| Shipping (Lbs.) / Net (Lbs) | 140 / 129 |

① Central Furnace heating designs are certified to ANSI Z21.47 / CSA 2.3

② Ratings shown are for elevations up to 2000 feet. For elevations above 2000 feet; Ratings should be reduced at the rate of 4% for each 1000 feet above sea level.

③ Based on U.S. Government Standard Tests.

④ The above wiring specifications are in accordance with National Electrical Code; however, installations must comply with local codes.

Mechanical Specifications

NATURAL GAS MODELS — Central heating furnace designs are certified to ANSI Z21.47 / CSA 2.3 for both natural and L.P. gas. Limit setting and rating data were established and approved under standard rating conditions using American National Standards Institute standards.

SAFE OPERATION — The Integrated System Control has solid state devices, which continuously monitor for presence of flame, when the system is in the heating mode of operation. Dual solenoid combination gas valve and regulator provide extra safety.

QUICK HEATING— Durable, cycle tested, heavy gauge **aluminized steel heat exchanger** quickly transfers heat to provide warm conditioned air to the structure. **Low energy power vent blower**, to increase efficiency and provide discharge of gas fumes to the outside, allows common venting with hot water heater.

BURNERS — Multi-port, in-shot burners will give years of quiet and efficient service. All models can be converted to **L.P. gas** without changing burners.

INTEGRATED SYSTEM CONTROL— Exclusively designed operational program provides total control of furnace limit sensors, blowers, gas valve, flame control and includes self diagnostics for ease of service.

AIR DELIVERY — The variable speed, direct-drive blower motor, with sufficient airflow range for most heating and cooling requirements, will switch from heating to cooling speeds on demand from room thermostat. The blower door safety switch will prevent or terminate furnace operation when the blower door is removed. (Fan relay and 35VA control transformer is standard).

STYLING— **Heavy gauge steel and "wrap-around" cabinet construction** is used in the cabinet with baked-on enamel finish for strength and beauty. The heat exchanger section of the cabinet is completely lined with foil-faced fiberglass insulation. This results in quiet and efficient operation due to the excellent acoustical and insulating qualities of fiberglass.

FEATURES AND GENERAL OPERATION — These High Efficiency Gas Furnaces employ a Hot Surface Ignition system, which eliminates the waste of a constantly burning pilot. The integrated system control lights the main burners upon a demand for heat from the room thermostat. Complete front service access.

- a. Low energy power venter.
- b. Vent proving differential switch.

American Standard

HEATING & AIR CONDITIONING

Since American Standard Heating & Air Conditioning has a policy of continuous product and product data improvement, it reserves the right to change specifications and design without notice.

Technical Literature - Printed in U.S.A.

American Standard
Heating & Air Conditioning
6200 Troup Highway
Tyler, TX 75707



| | |
|-----------------|--------------------|
| Library | - |
| Product Section | - |
| Product | Furnace |
| Model | ADD2-A9V |
| Literature Type | Submittal |
| Sequence | - |
| Date | 06/11 |
| File No. | ADD2B060A9V-SPEC-1 |
| Supersedes | ADD060R9V-SPEC-1A |